

# LT40-8UL · Recessed Center Logging Trailer

**PITTS** Trailers®  
Since 1976

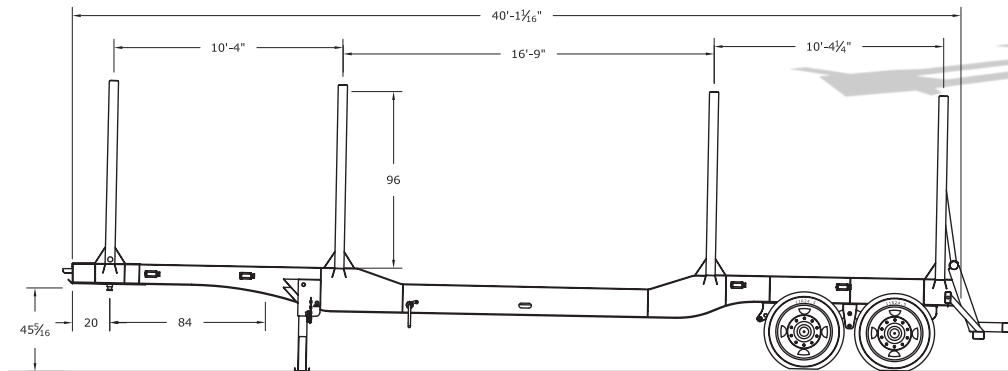

Sourcewell

Awarded Contract

Contract # 092922-PTT

Since 1976, Pitts has built trailers for the construction, commercial and forestry markets tough enough for every job and priced to make you profitable.

Pitts Trailers is the world's largest and only complete line forestry manufacturer, moving the forestry transportation market forward with its log trailers, open and closed top chip vans, moving floor vans, and hydraulic elevating trailers with crawler suspension for knuckle boom loaders.

# LT40-8UL Standard Features



<b>WEIGHT</b>
8,650 lbs +/- 3%
<b>MAINFRAMES</b>
23" Fabricated Beam, T-1 Steel – 8" Center Drop Design
<b>AXLES</b>
(2) 25,000 lb Capacity, 77 1/2" Track
Anti Lock Brake System
16.5" x 7" Air Brakes
Type 30/30 Brake Chambers
<b>SUSPENSION</b>
Hutch 9700 3 Point Heavy Duty 4 Leaf Steel Spring
<b>WHEELS</b>
10 Hole Unimount
<b>TIRES</b>
11R24.5 Radials
<b>BOLSTERS</b>
4" x 10" Tubing, 70K Yield
<b>STANDARDS</b>
4.5" x 4.5" Tubing, 100K Yield
<b>LANDING GEAR</b>
4.5" x 4.5" Tubing, 100K Yield - Patented Lock N' Go Landing Gear
<b>BUMPER</b>
4" x 6" Tubing, 70K Yield

<b>AIR TANK</b>
Covered w/ Channel Iron
<b>WINCHES</b>
With 30' Nylon Straps and Handles
<b>PROTECTIVE COATING</b>
High quality 2-part black acrylic urethane
High quality 2-part primer
White blasted and cleaned prior to painting

## OPTIONS

Greaseless Revolver Coupling System  
Aluminum Wheels  
Grapple Bar  
Vulcan or SI Electronic Scales (Air Scale Option  
Also Available)  
Single Point Spring Suspension (w/ Lift Axle  
Option)

Air Ride Suspension (w/ Lift Axle Option)  
Heavy Duty Headboard  
Slidable Bolsters  
Disc Brakes  
11R22.5 Radial Tires  
Custom Designs Available

*Note: All specifications are subject to change without prior notification. All dimensions and weights are approximate. Trailers pictured in this brochure may feature optional equipment. Axle placement and legal load ratings are dependent upon federal, state, and local regulations, GAWR and tire ratings. Copyright © 2019 Pitts Enterprises, Inc. (published). All rights reserved.*