

PT22 · Pintle Hitch Logging Trailer

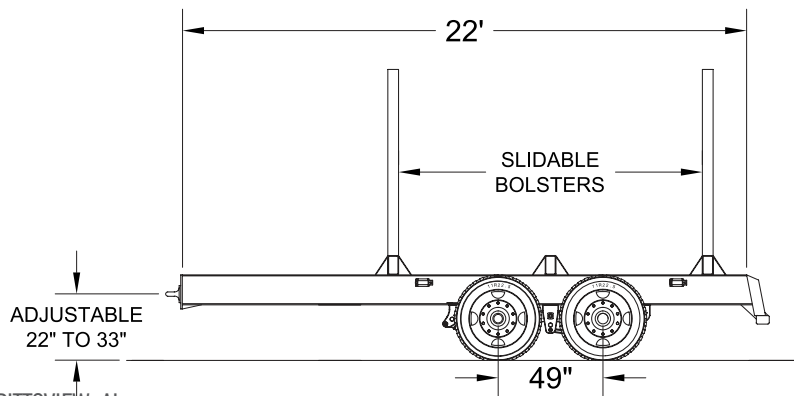

Sourcewell
Awarded Contract
Contract # 092922-PTT



Since 1976, Pitts has built trailers for the construction, commercial and forestry markets tough enough for every job and priced to make you profitable.

Pitts Trailers is the world's largest and only complete line forestry manufacturer, moving the forestry transportation market forward with its log trailers, open and closed top chip vans, moving floor vans, and hydraulic elevating trailers with crawler suspension for knuckle boom loaders.

PT22 Standard Features



CAPACITY
55,000 lbs. GVWR
OVERALL LENGTH
22'
OVERALL WIDTH
102"
MAINBEAMS
14" Wide Flange Mill Roll I-Beams
SUSPENSION
3 Point, 4 Spring - 56,000 lb Capacity
AXLES
(2) 25,000 lb Capacity, 77 1/2" Track
49" Axle Spacings
Auto Slack
Anti Lock Brake System
16.5" x 7" Air Brakes
Type 30/30 Brake Chambers
WHEELS
Disc - Hub Piloted
TIRES
11R24.5 Radials
TANDEM SETTING
60" Standard
DRAW BAR
g.t.w. 60,000 lbs. - 3" Eye - 4 Position
TOUNGE
Continuation of Mainframe
SAFETY CHAIN
1/2" High Test
LANDING GEAR
Single Speed Drop Leg
BOLSTERS
(2) 4" x 10" x 102" Tubing, 70K Yield

BOLSTER SETTINGS
1-2: 12' 3-4: None 5-6: None 7-8: None
STANDARDS
5" x 5" Tubing, 100K Yield
STANDARD HEIGHT
1st: 96" Overall 2nd: 96" Overall 3rd: None 4th: None 5th: None 6th: None 7th: None 8th: None
D. BOLSTER / RMV RISER
Dead Bolster
WINCHES
(2) 30' Nylon Straps and Handles on Frame
BUMPER
4" x 6" Tubing, 70K Yield
AIR TANK
Covered w/ Channel Iron
BRAKES
Type 30/30 Spring Brakes - 2 Axle
WIRING
D.O.T. sealed wiring harness
PROTECTIVE COATING
High quality 2-part black acrylic urethane
High quality 2-part primer
White blasted and cleaned prior to painting

OPTIONS

Revolver greaseless coupling system	PITTS-air lift axle on a single point suspension
Aluminum wheels	Air ride suspension
Grapple bar	Headboard
Electronic or air scales	Slideable bolsters
Single point spring suspension	Custom designs

Note: All specifications are subject to change without prior notification. All dimensions and weights are approximate. Trailers pictured in this brochure may feature optional equipment. Axle placement and legal load ratings are dependent upon federal, state, and local regulations, GAWR and tire ratings. Copyright © 2019 Pitts Enterprises, Inc. (published). All rights reserved.