

LP40-4UL · Low Profile Logging Trailer

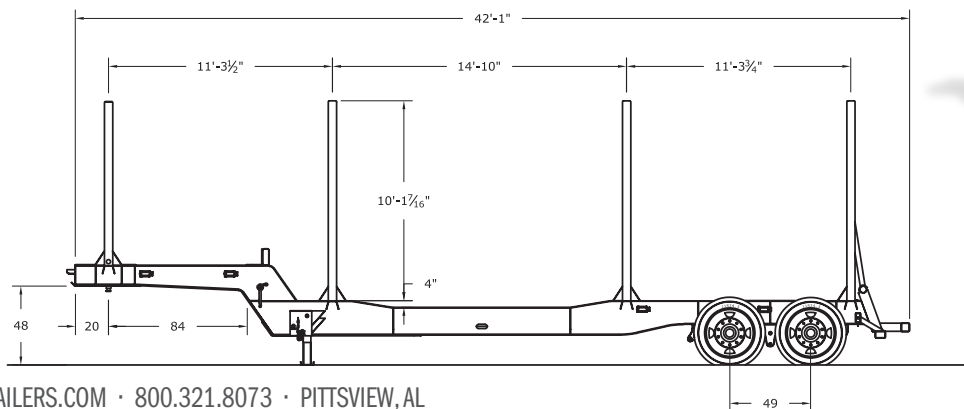

PITTSTAILERS.COM · 800.321.8073 · PITTSVIEW, AL

Since 1976, Pitts has built trailers for the construction, commercial and forestry markets tough enough for every job and priced to make you profitable.

Pitts Trailers is the world's largest and only complete line forestry manufacturer, moving the forestry transportation market forward with its log trailers, open and closed top chip vans, moving floor vans, and hydraulic elevating trailers with crawler suspension for knuckle boom loaders.



LP40-4UL Standard Features



WEIGHT
9,900 lbs +/- 3%
MAINFRAMES
20" Fabricated Beam, T-1 Steel - Low Profile Design w/ 4" Drop in Center
AXLES
(2) 25,000 lb Capacity, 77 1/2" Track
Anti Lock Brake System
16.5" x 7" Air Brakes
Type 30/30 Brake Chambers
SUSPENSION
Hutch 9700 3 Point Heavy Duty 4 Leaf Steel Spring
WHEELS
10 Hole Unimount
TIRES
11R24.5 Radials
BOLSTERS
4" x 9.5" Tubing, 70K Yield
STANDARDS
4.5" x 4.5" Tubing, 100K Yield
LANDING GEAR
4.5" x 4.5" Tubing, 100K Yield - Patented Lock N' Go Landing Gear
BUMPER
4" x 6" Tubing, 70K Yield

AIR TANK
Covered w/ Channel Iron
WINCHES
With 30' Nylon Straps and Handles
PROTECTIVE COATING
High quality 2-part black acrylic urethane
High quality 2-part primer
White blasted and cleaned prior to painting

OPTIONS

Greaseless Revolver Coupling System
Aluminum Wheels
Grapple Bar
Vulcan or SI Electronic Scales (Air Scale Option Also Available)
Single Point Spring Suspension (w/ Lift Axle Option)

Air Ride Suspension (w/ Lift Axle Option)
Heavy Duty Headboard
Slidable Bolsters
Disc Brakes
11R22.5 Radial Tires
Custom Designs Available