

LB25-33CS · Fixed Neck Lowboy

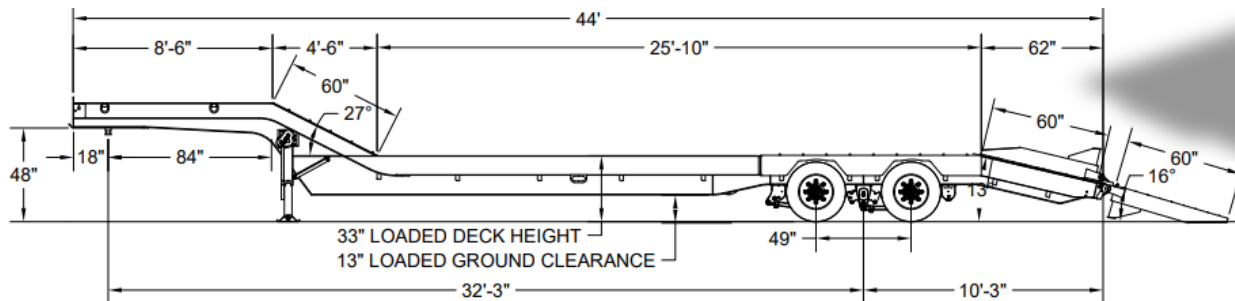

Since 1976, Pitts has built trailers for the construction, commercial and forestry markets tough enough for every job and priced to make you profitable.

The workhorses of the heavy haul division, include a Hydraulic Detachable, Hydraulic Tail, Fixed Neck and Tag-Along with every feature you desire.

LB25-33CS Standard Features



CAPACITY
25 tons In 16' (GAWR and tire ratings determine legal payloads)
ESTIMATED TARE WEIGH
13,100 lbs ± 3%
LOAD BASE
16' rigid point load centered in deck
DIMENSIONS
Overall: 8' 6" width x 44' length
Clear deck length: 25'10", (flat deck design)
Deck height under full load: 33" (ground clearance 13")
Rear bogie height: 33"
GOOSENECK DESIGN
48" nominal loaded 5th wheel height
Fixed neck to deck connection
Full width wood filled top deck
Full width 27° steel smooth plate, wood filled between main beams with loading slope and traction bars
84" swing radius
Landing gear - two speed - 50,000 lbs.
Toolbox in front of neck
DECK DESIGN
Main longitudinal members 20" fabricated with positive camber with 10" side rails level deck design
8" I-beam crossmembers, with knee braces on 42" centers
1 1/2" nominal apitong decking
BOGIE DESIGN
Wheel wells covered with formed steel smooth plate and traction bars
5' dovetail covered with steel check plate and traction bars
6'x 2' heavy duty spring assisted, self cleaning, rear loading ramps
AXLES
(2) Heavy-duty axles with 49" spread
22,500 lbs nominal capacity per axle (GAWR determined by suspension type, brakes, tires and other components)
Tapered spindle axles

HUBS
Hub-piloted 8-stud mount
Outboard cast drums
BRAKES
12 1/4" x 7 1/2"
Heavy-duty brake drums, outboard mount
Automatic slack adjusters
Type 30/30 parking brakes on (2) axles
SUSPENSION
AXN heavy duty 44,800 lbs 3 point heavy duty 3 leaf steel spring
WHEELS
(8) Steel disc wheels 6.75 x 17.5 with 235/ 75R 17.5 H-ply tires
ELECTRICAL SYSTEM
Fully sealed wiring harness with LED lights
Marker lights and mid-turn signals
(2) Oval stop, tail and turn lights per side on rear
PROTECTIVE COATING
High quality 2-part black acrylic urethane
High quality 2-part primer
White blasted and cleaned prior to painting
LASH RINGS
(8) Pair (16 total), bent D-rings
FLAG HOLDERS
Heavy Duty Drop Leg 2-Speed

Note: All specifications are subject to change without prior notification. All dimensions and weights are approximate. Trailers pictured in this brochure may feature optional equipment. Axle placement and legal load ratings are dependent upon federal, state, and local regulations, GAWR and tire ratings. Copyright © 2019 Pitts Enterprises, Inc. (published). All rights reserved.