

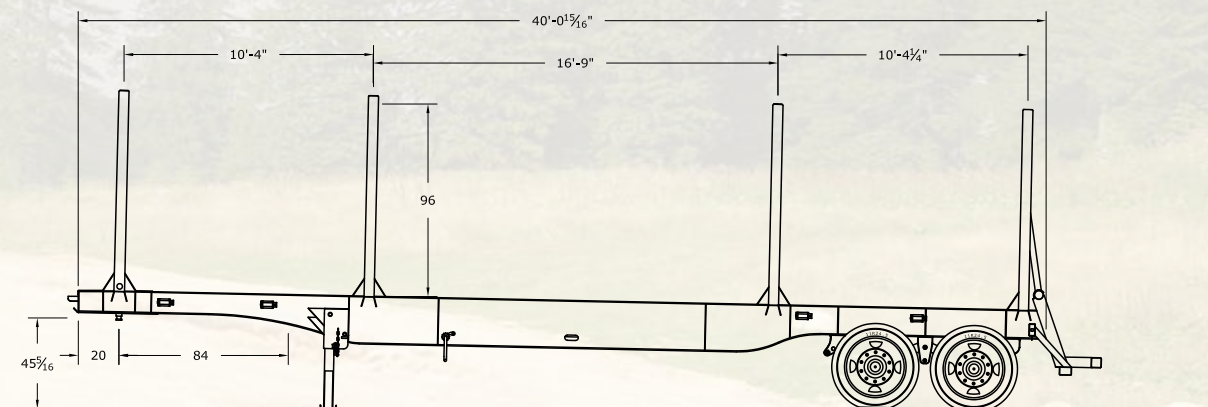

“You’re Ahead With A Pitts Behind”



## STANDARD EQUIPMENT

### AXLES

- ▶ 25,000 lb capacity, 77 ½" track
- ▶ Anti Lock brake system
- ▶ 16 ½" x 7" air brakes
- ▶ Type 30/30 brake chambers

### SUSPENSION

- ▶ Hutch 9700 3 point heavy duty 4 leaf steel spring

### WHEELS

- ▶ 10 hole unimount

### TIRES

- ▶ 11R24.5 radials

### BOLSTERS

- ▶ 4" x 10" tubing, 70K yield

### STANDARDS

- ▶ 5" x 5" tubing, 70K yield

### LANDING GEAR

- ▶ 4 ½" x 4 ½" tubing, 100K yield

### BUMPER

- ▶ 4" x 6" tubing, 70K yield

### AIR TANK

- ▶ Covered

### WINCHES

- ▶ With 30' nylon straps

### MAINFRAMES

- ▶ 23" fabricated beam, T-1 steel

### TOOL BOX

- ▶ (1) Standard

### PAINT

- ▶ White Blasted, Two Part Primer, Two Part PPG Black Acrylic Urethane. Black is Standard.

Popular options: Revolver greaseless coupling system \* Aluminum wheels \* Grapple bar \* electronic or air scales \* single point spring suspension \* PITTS-air lift axle on a single point suspension \* Air ride suspension \* headboard \* slideable bolsters \* custom designs

PITTSTRAILERS.COM

LEARN MORE ABOUT PITTS TRAILERS, AND JOIN US ON FACEBOOK

800.321.8073

PITTSVIEW, AL



*Note: All specifications are subject to change without prior notification. All dimensions and weights are approximate. Trailers pictured in this brochure may feature optional equipment. copyright © 2013 Pitts Enterprises, Inc. (publ). Pate. All rights reserved.*